

PLATINUM MANUFACTURING

PLATINUMMFG@AOL.COM

BUMPER PULL HORSE TRAILER ORDER



CUSTOMER: **TRL. UNLIMITED/**

SERIAL NO: **6979 2014 MODEL**

E.C.D.: \_\_\_\_\_ DATE: **11-07-13**

**P.P. WHITE EXTERIOR FINISH**

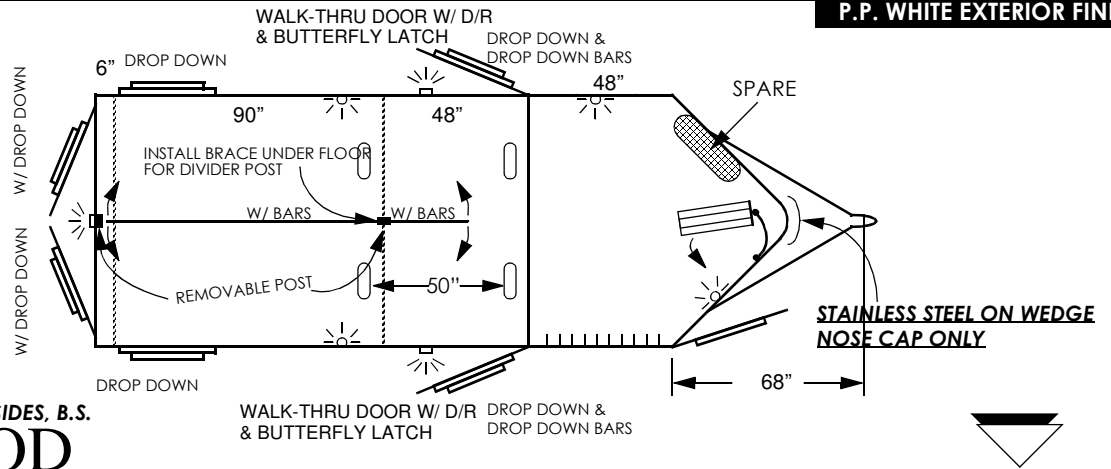

STD. - TAPER WHEEL WELLS UP TO SIDES, B.S.

# WARMBLOOD

MODEL: **2-HORSE, T.B. B.P.** WIDTH: **7'-0"** LENGTH: **16'-0"** HEIGHT: **8'-0"**

1	2 5/16" B.D. Coupler: <b>STD.</b>	Jack: <b>STD.</b>
2	Axles Qty: <b>2-102"</b> Type: <b>RUBBER TORSION</b> Capacity: <b>5200#</b>	Hub: <b>8-BOLT</b>
3	Brakes: <b>ELECTRIC</b> Mntg. Brkt.: <b>80"</b>	Overhang:
4	Tires: <b>235/85R16E 10-PLY</b> Wheels: <b>16" X 6" W/ SIMULATORS</b> Spare: <b>YES</b>	
5	Nose: <b>WEDGE NOSE</b>	
6	Sides: <b>SLATTED W/ SMOOTH ALUM. AT TOP</b> Floor: <b>SMOOTH ALUM. PLATE</b>	

**STANDARD EQUIPMENT**

		PERMANENT	FLOOR MATS HORSE COMPT.	X	
7	BULKHEAD WALL	X	NONE	X	
8	REAR STORAGE	NO	RUBBER C.S. WALL AND S.S. WALL	X	
9	FULL WIDTH REAR RAMP	X	SEE LINE 24	X	
10	DRESSING ROOM DOOR	X	STD. W/ WINDOW, C.S. OF WEDGE	X	
11	FEED DOORS (DROP DOWN)	NO	NONE	X	STD. - D/R FLOOR (GRAY)
12	FRONT WALK-THRU DOOR	2	1 @ EACH SIDE W/ DROP DOWN	2	SWING OUT IN D/R
13	FEED BAGS	2	SQUARE	10	B/H WALL IN D/R
14	STD. HALF DIVIDERS	1	DIV. W/ BARS AND HEAD SHIELD W/ BARS	NO	NONE
15	INSIDE TIE RINGS, 2 PER	4	FOUR	NO	NONE
16	OUTSIDE TIE RINGS, 2 PER	4	2 EACH SIDE	4	
17	TWO-WAY ROOF VENTS	X	2 PER HORSE SEE ABOVE	X	
18	BUTT BAR (LAST HORSE)	2	1 PER HORSE	X	
19	BREAST BAR (FIRST HORSE)	2	1 PER HORSE	X	???

- 20 **OPTIONS:**
- 21 **(3) OUTSIDE HALOGEN LOADING LIGHTS, 1 @ REAR, 1 S.S., 1 C.S.**
  - 22 **NOTE: REMOVABLE CENTER POST, REMOVABLE DIVIDER & SWINGING HEAD SHIELD**
  - 23 **(1) REMOVABLE REAR CENTER POST**
  - 24 **50/50 DOUBLE REAR DOORS W/ (2) DROP DOWNS, 1 ON EA. DOOR**
  - 25 **NOTE: BUTT BARS WILL HOLD DIVIDER IN PLACE**
  - 26
  - 27
  - 28 **(2) DROP DOWN FEED DOORS, 1 EACH ESCAPE**
  - 29 **(2) DROP DOWN FEED DOORS, 1 EACH SIDE @ HIP**
  - 30 **(2) DROP DOWN WINDOW BARS FOR FEED DOOR @ HEAD, 1 EA. SIDE**
  - 31
  - 32 **INSULATE/LINE ROOF & TOP RAIL FULL LENGHT OF TRAILER**
  - 33 **STAINLESS STEEL ILO ALUM. ON WEDGE NOSE CAP ONLY**

Coupler:	Subframe:	Top Rail Length:
Floor:	Door Notch Out:	Wedge S.S.:
Side C.S.:	Side S.S.:	Wedge C.S.:
Divider(s):		B/H Wall:
Door(s):		
VIN:	GVWR:	SHIP WT.:
		DATE: